



Relief Modular Valve

50 to 300 ℓ /min
25,35MPa

Features

- ① This modular relief valve provides maximum pressure control for a hydraulic circuit.
- ② Wide ranging applicability Maximum Operating Pressure: 25, 35MPa {255, 357kgf/cm²} Pressure Adjustment Range: 0.8 to 25, 35MPa {8.2 to 255, 357kgf/cm²}
- ③ Shockless unload, 2-pressure control, and other configurations are possible by switching the solenoid valve. Contact your agent for details.

Specifications

Model No.	Nominal Diameter (Size)	Maximum Working Pressure MPa{kgf/cm ² }	Maximum Flow Rate ℓ /min	Pressure Adjustment Range MPa{kgf/cm ² }	Weight kg	Gasket Surface Dimensions
OR-G01-P1-20 P3	1/8	25 {255}	50	* to 7{ * to 71.4} 3.5 to 25{35.7 to 255}	1.5	ISO 4401-03-02-0-94
OR-G01-W1-20 W3				* to 7{ * to 71.4} 3.5 to 25{35.7 to 255}	2.3	
OR-G01-A1-21 A3				* to 7{ * to 71.4} 3.5 to 25{35.7 to 255}	1.6	
OR-G01-B1-21 B3				* to 7{ * to 71.4} 3.5 to 25{35.7 to 255}	1.6	
OR-G03-P1-(V)-J50 P3	3/8	25 {255}	80	* to 7{ * to 71.4} 3.5 to 25{35.7 to 255}	3.1	ISO 4401-05-04-0-94
OR-G03-W1-J50 W3				* to 7{ * to 71.4} 3.5 to 25{35.7 to 255}	3.9	
OR-G03-A1-J50 A3				* to 7{ * to 71.4} 3.5 to 25{35.7 to 255}	3.1	
OR-G03-B1-J50 B3				* to 7{ * to 71.4} 3.5 to 25{35.7 to 255}	3.1	
ORH-G04-P1-10 P3 P5	1/2	35 {357}	300	* to 7{ * to 71.4} 3.5 to 25{35.7 to 255} 7 to 35{71.4 to 357}	7.0	ISO 4401-07-06-0-94

Note) *See the Flow Rate - Low Pressure characteristics on page D-17 for information about items marked with an asterisk.

● Handling

- ① When using a remote control valve in a vent circuit, certain vent circuit pipe capacities can cause vibration. Because of this, thick steel pipe with an inside diameter of $\phi 4$ mm that is no longer than three meters is recommended. Vent piping cannot be used with the 01 size. If a vent port is required for the 03 size, add the auxiliary code "V".
- ② For use as a safety valve, use a pressure override that is higher than the required circuit pressure.
- ③ Make sure that tank port back pressure is no greater than 0.2MPa {2.0kgf/cm²}.
- ④ A small control flow rate can cause pressure instability. Use a control flow rate that is in accordance with the values shown below.
01 size: At least 5 ℓ /min
03 size: At least 8 ℓ /min
04 size: At least 8 ℓ /min
For applications that require a flow rate that is less than the minimum flow rate, use an ORD-G** direct type relieve modular valve.
- ⑤ Note that a sub plate and installation bolts are not included. See pages D-90 through D-95 if these items are required.
- ⑥ 04 series modular valves do not have an L (DR₂) drain port, so they cannot be used in combination with pressure center type solenoid valves (D).
- ⑦ Connect OR-603-W*-(J) 50 to the two T-ports on the tanks.

Understanding Model Numbers

01: 03 size

OR-G 03 - P 1 - (K) - J50

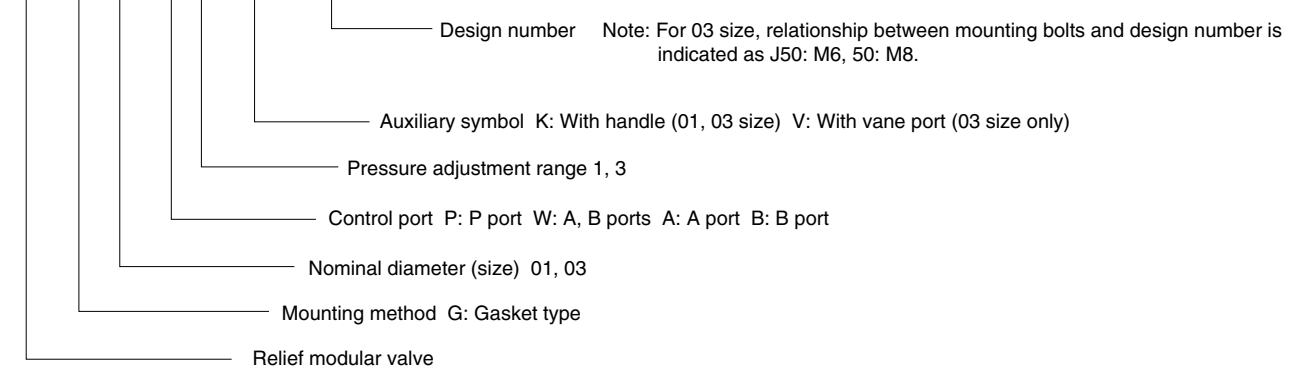

Understanding Model Numbers

04 size

ORH-G 04 - P 5 - 10

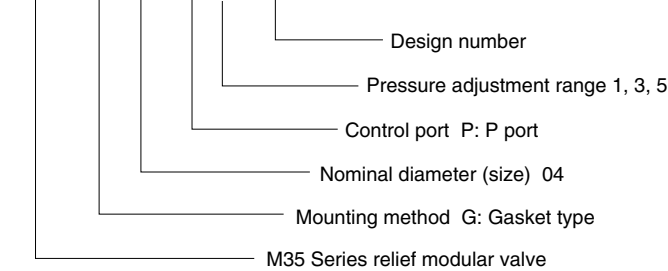

Installation Dimension Drawings

Note) Pressure is increased by clockwise (rightward) rotation of the adjusting screw (bolt), and decreased by counterclockwise (leftward) rotation.

OR-G01-P*-20

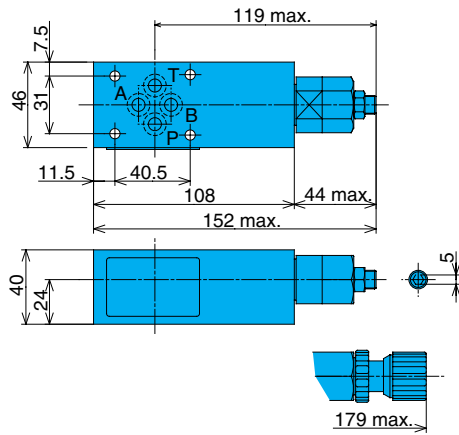

OR-G01-W*-20

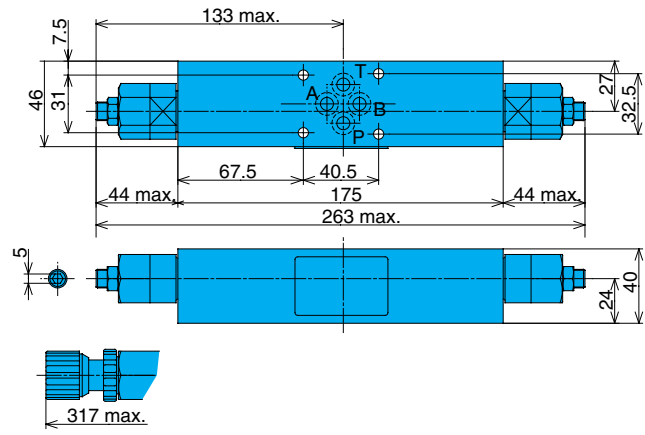

OR-G01-A*-21

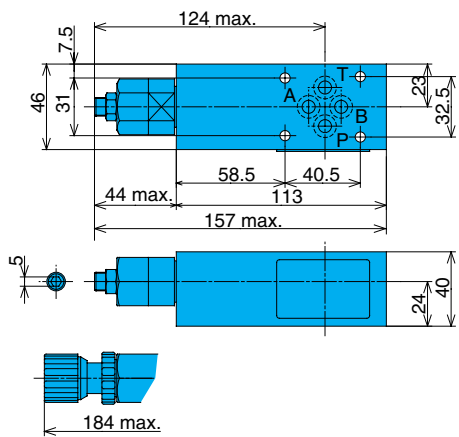

OR-G01-B*-21

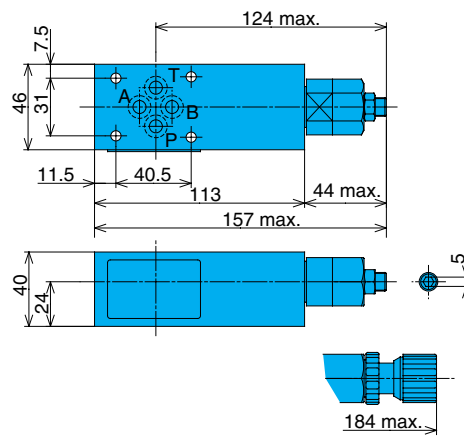

OR-G03-P*-(V)-J50

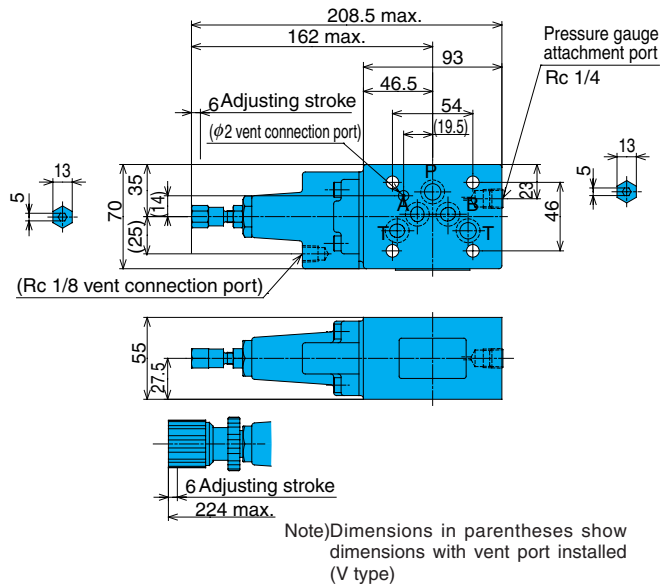

OR-G03-W*-J50

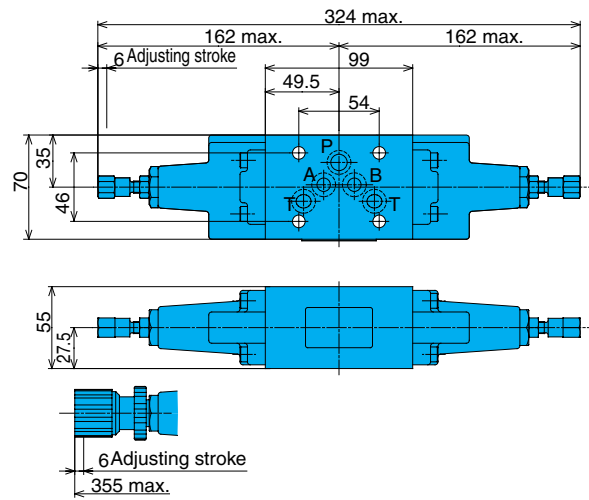

OR-G03-A*-J50

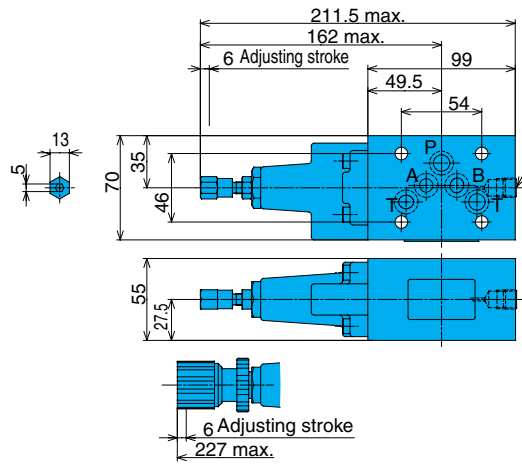

OR-G03-B*-J50

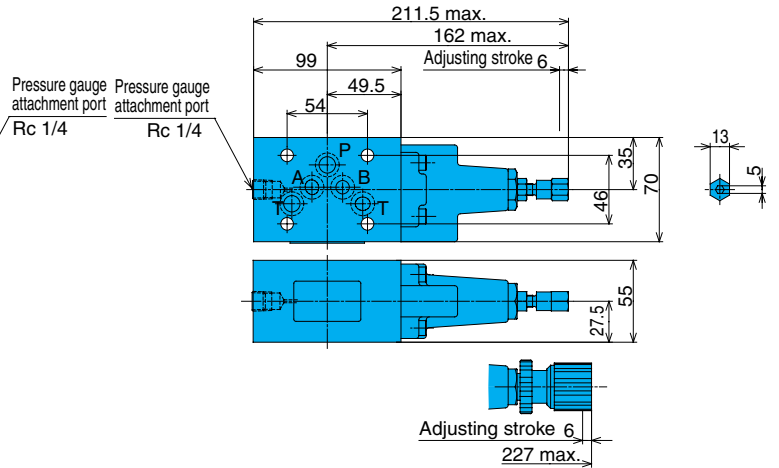

ORH-G04-P*-10

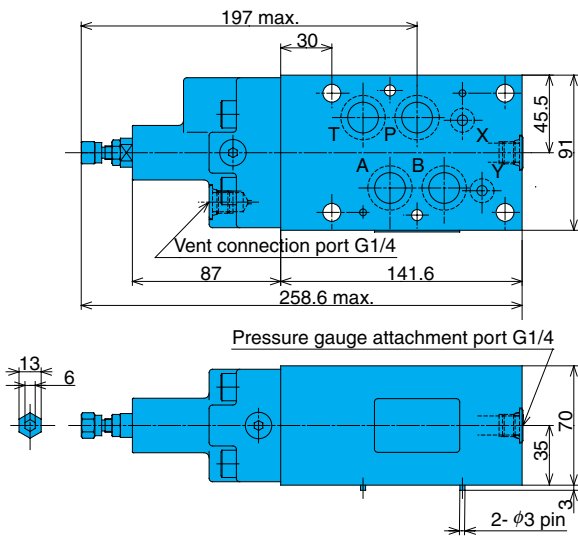

Performance Curves

Differential Hydraulic Fluid Viscosity 32mm²/s

Flow Rate – Minimum Pressure Characteristics

OR-G01-*1-20(21)

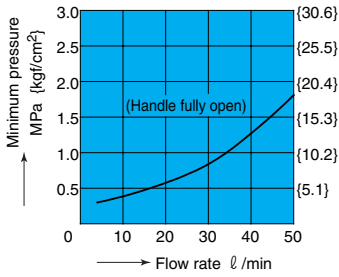

OR-G03-P1-J50

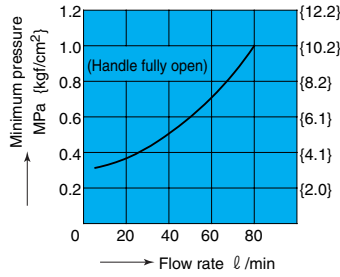

ORH-G04-P*-10

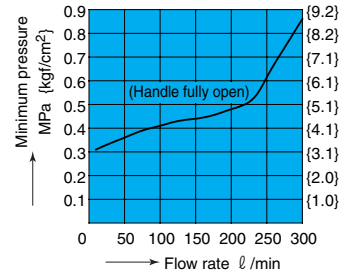

Pressure – Flow Rate Characteristics

OR-G01-**-20(21)

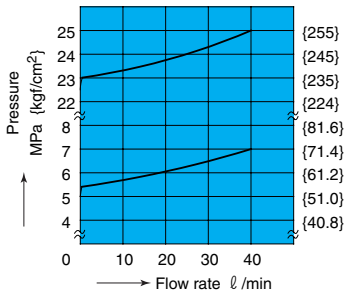

OR-G03-P*-J50

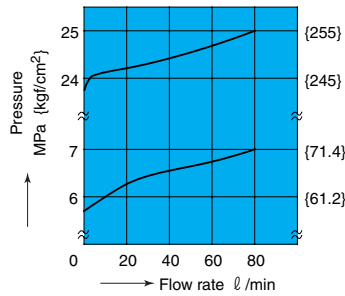

ORH-G04-P*-10

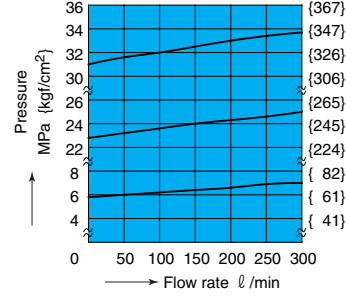

Number of Adjusting Screw Rotations – Pressure Characteristics

OR-G01-P*-20

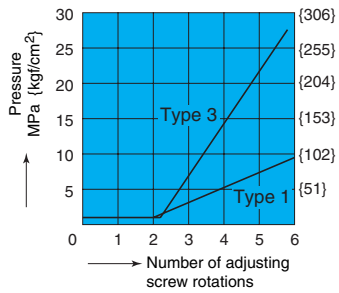

OR-G03-P*-(J)50

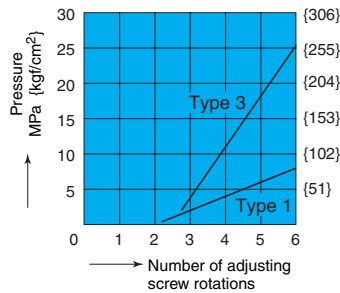

ORH-G04-P*-10

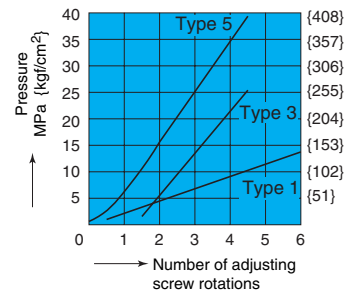

Cross-sectional Drawing

OR-G01-P*-20

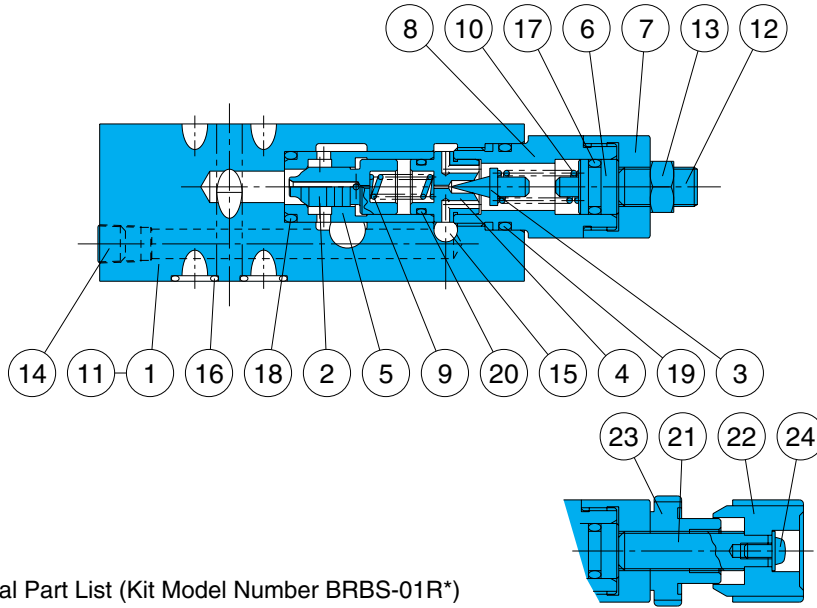

Part No.	Part Name
1	Body
2	Spool
3	Poppet
4	Seat
5	Sleeve
6	Plunger
7	Bushing
8	Retainer
9	Spring
10	Spring
11	Plate
12	Screw
13	Nut
14	Plug
15	Plug
16	O-ring
17	O-ring
18	O-ring
19	O-ring
20	O-ring
21	Screw
22	Knob
23	Nut
24	Screw

Seal Part List (Kit Model Number BRBS-01R*)

Part No.	Part Name	Part Number	Q'ty			
			P	W	A	B
16	O-ring	1B-P9	4	4	4	4
17	O-ring	1A-P10A	1	2	1	1
18	O-ring	1B-P14	1	2	1	1
19	O-ring	1B-P18	1	2	1	1
20	O-ring	AS568-013(Hs90)	1	1	1	1

Note) 1. O-ring 1A/B-** refers to JIS B2401-1A/B.
2. Specify P, W, A, or B for the asterisk (*) in the kit model number.

OR-G03-P*-V-J50

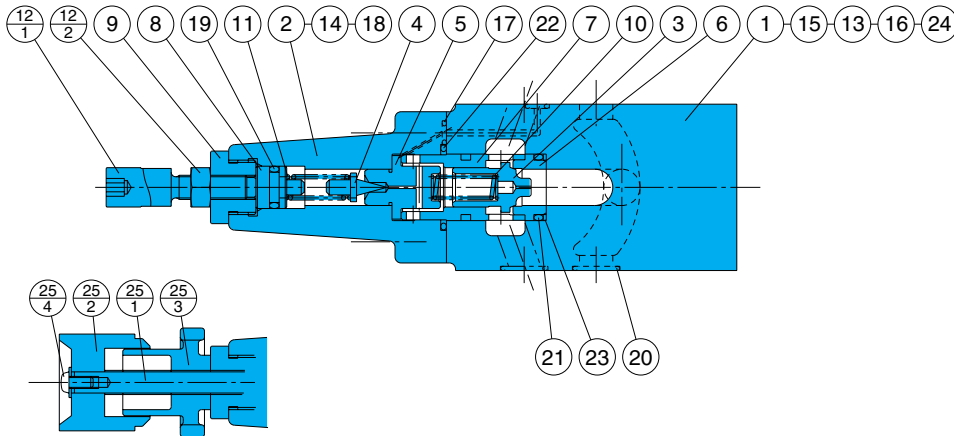

Part No.	Part Name
1	Body
2	Cover
3	Spool
4	Poppet
5	Seat
6	Seat
7	Sleeve
8	Plunger
9	Retainer
10	Spring
11	Spring
12	Screw kit
12 ₁	Screw
12 ₂	Nut
13	Plate
14	Screw
15	Plug
16	Plug
17	O-ring
18	O-ring
19	O-ring
20	O-ring
21	O-ring
22	O-ring
23	Backup ring
24	Pin
25	Handle kit
25 ₁	Screw
25 ₂	Knob
25 ₃	Nut
25 ₄	Screw

Seal Part List (Kit Model Number BRES-03R*)

Part No.	Part Name	Part Number	Q'ty		
			P/A/B	W	PV
17	O-ring	1B-P5	—	—	2
18	O-ring	1B-P7	1	2	1
19	O-ring	1A-P10A	1	2	1
20	O-ring	AS568-014(Hs90)	5	5	5
21	O-ring	1B-P18	2	4	2
22	O-ring	AS568-119(Hs90)	1	2	1
23	Backup ring	T2-P18	1	2	1

Note) 1. O-ring 1A/B-** refers to JIS B2401-1A/B.
2. Backup ring indicates JIS B2407-T2-**.
3. Specify P, W, or PV for the asterisk (*) in the kit model number.

ORH-G04-P*-10

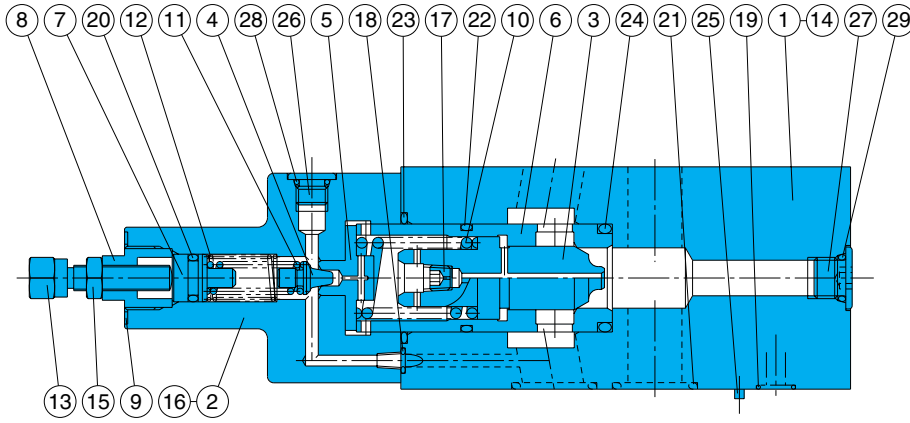

Part No.	Part Name
1	Body
2	Cover
3	Spool
4	Poppet
5	Seat
6	Sleeve
7	Plunger
8	Retainer
9	Plate
10	Spring
11	Spring
12	Spring
13	Screw
14	Plate
15	Nut
16	Screw
17	Choke
18	O-ring
19	O-ring
20	O-ring
21	O-ring
22	O-ring
23	O-ring
24	O-ring
25	Pin
26	Plug
27	Plug
28	O-ring
29	O-ring

Seal Part List (Kit Model Number BRKS-04RP)

Part No.	Part Name	Part Number	Qty
18	O-ring	1B-P5	1
19	O-ring	AS568-012(Hs90)	2
20	O-ring	1A-P11	1
21	O-ring	AS568-118(Hs90)	4
22	O-ring	AS568-122(Hs90)	1
23	O-ring	AS568-127(Hs90)	1
24	O-ring	1B-P28	1
28	O-ring	1B-P8	3
29	O-ring	1B-P11	3

Note) O-ring 1A/B-** refers to JIS B2401-1A/B.